

## More important tips

- Sliding glass doors need screws in the upper frame to prevent removal by lifting the door from the track.
- Be sure your house numbers are clearly visible from the street.
- Secure your irreplaceable valuables in a safe. Bolt the safe to the sub floor or wall studs if possible.
- A good house alarm system with an exterior siren should be the 'icing on the cake' after reinforcing the entry points to your home.
- Do not leave notes outside announcing your absence.
- When leaving out of town for long periods, request a "Close Patrol" from your nearest police station.

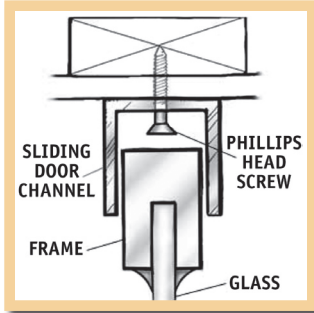

## Other brochures available to enhance home security:

- Operation I.D.
- What is Suspicious
- Personal Safety

Do you want to start a Community Watch in your neighborhood or sign up for one of our community based programs?

Just visit the Crime Prevention web page at [arlingtonpd.org](http://arlingtonpd.org) for applications and program information.



City of Arlington Police Department  
Community Services Division  
P.O. Box 1065, MS 04-0120  
Arlington, TX 76004-3231

Phone: 817-459-5725  
Fax: 817-459-5797  
[Arlingtonpd.org](http://Arlingtonpd.org)

# A Guide to Home Security



**City of Arlington**  
Police Community Services Division  
817-459-5725 [www.arlingtonpd.org](http://www.arlingtonpd.org)

## Don't give a burglar a helping hand

Most burglars prefer quick and undetected access into your residence.



Reinforcement to the entry points of your home can determine the difference of a

successful or unsuccessful burglary.

## Survey your home landscaping

- Your landscaping should allow you to have 'maximum surveillance' from the inside out to the street.
- Trim all tree branches 7' up from the base.
- All hedges should be trimmed down 6" below the base of each window.
- Be sure your front door is highly visible from the street and does not provide a hiding spot for burglars.

## Lighting

- Criminals prefer darkness to conduct illegal activity.
- Keep your porch and driveway lights on throughout the night with a minimum 70-watt bulb to allow high visibility and discourage trespassers.
- Consider energy saving light bulbs such as fluorescent spiral style that use 13 watts of energy yet can produce a 70 watt output.



## Fencing

Fencing controls access onto properties and diverts traffic.



- A true security fence is a minimum of 8' tall.
- Wood fencing can conceal intruders from a neighbors vision and is also a popular target for graffiti.
- Chain link and vinyl fencing are prohibited from residential use in Arlington per City Ordinance.
- Although expensive, wrought iron provides the best over-all security fencing due the increased visibility and resistance to cutting and climbing.

## Doors

- All exterior doors should be a minimum 1 3/8" thick and be composed of solid wood core or heavy gauged metal.
- Secure the door frame with hardened steel screws that are a minimum 3" in length. This will secure the frame into the wall studs and help resist a fracture resulting from a door kick.
- Install a peephole with a 190 fisheye lens.



## Door Locks

- When moving into a new home or apartment, have the locks re-keyed or replaced.
- Every exterior door should be equipped with some form of deadbolt lock.
- A single cylinder deadbolt lock with a minimum 1" throw bolt is the most recommended.

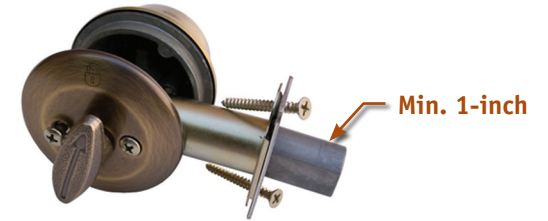

- There should not be any breakable glass windows within 40" of a deadbolt lock.

### Note:

Double cylinder deadbolt locks are a safety hazard and violation of City of Arlington Fire Code.

## Windows

All exterior windows need to be equipped with secondary locking devices to provide additional backup to the standard locks.

